



## DESIGN AND CONSTRUCTION OF AN AUTOMATIC TEMPERATURE REGULATOR IN POULTRY ARENA USING ATMEL 8052 MICROCONTROLLER



K. O. Ojo\*, O. A. Benard and J. Ailegbo

Department of Science Laboratory Technology, University of Benin, Edo State, Nigeria

\*Corresponding author: [meetengrodu@gmail.com](mailto:meetengrodu@gmail.com)

Received: November 03, 2018 Accepted: March 24, 2019

**Abstract:** An automatic temperature regulator is a system for controlling and monitoring the internal condition of livestock's in poultry environment. Microcontroller is a single based data chip that is used in programming information or instructions in an automatic temperature regulator system. Temperature sensor LM35 is used to sense the changes of temperature and it gives a voltage proportional to the environmental change, LM35 gives output of 10 mV (0.01 volts) per degree Celsius, it also covert physical signal to electrical signal. The chick physiology is crucial and must be maintained according to changes in temperature. Lighting during brooding should be at the brightest intensity to encourage chick activity thus assisting them to locate feed and water. Once they learn where feed and water are located (somewhere around 7 to 10 days of age), the light intensity and duration should be reduced. The used of an automatic temperature regulator in poultry should be encouraged in agricultural extension and other field of electronics.

**Keywords:** Temperature, microcontroller, poultry, regulator

### Introduction

Poultry farming is divided into two namely; (1) Production of Egg and (2) Production of Meat. By using the application of wireless sensor network, quality of chicken can be improve ultimately, leads to improving the human health. In this research wearable wireless sensor was found to detect the infected chickens, the overall production, quality and economy can be improved by the use of automated system. Advanced technique of wireless sensor network and mobile network to control and automatically monitor environmental parameters of poultry, Personnel can be able to monitor environmental parameters by sending parameters like temperature and humidity back to the programmable system (Srvanth sand Abraham, 2015). If system doesn't receive command from register mobile number, then it will automatically perform its action. Hence by using this modern technique system that provides a modern technique for farm automation. This system should be able to monitor the surrounding parameters of poultry environment such as humidity, temperature, climate quality, the filter and fan switches. This system is found very simple and useful for farmers, as they can effectively control the poultry farm at any time and from anywhere. It is observed that modern chicken farming is more easy and useful as compare to traditional chicken farming with the help of modern technique. For a complete care of chicken it is important to monitor and control the environment of poultry for the better growth of chickens (RupeshI *et al.*, 2014). The Poultry sheds can be controlled 24 h by automation. It's help to provide an optimum output by reducing manpower in poultry. Chicken are considered as one of the essential needs of man when it comes to food. Thus, it is important that the food we take is fresh and hygienic. A new technology has been developed for ventilation of broiler houses for livestock. An Automated Temperature System controls the conditions inside the broiler house based on the requirements specific to the age of the chicken. Air movement is one of the most effective

methods of cooling birds during hot weather. As air moves over a bird's hot body, heat is removed from the bird, making it normal by regulating its internal environment (May and Lott, 2001).

Data Acquisition applications were structured by software programs settled using several programming languages as BASIC, C, FORTRAN, Java, lisp, Pascal. DAQ based on PDA for dairy system was introduced to save manpower, improve work efficiency and to solve the problems of management for effective information collections and technical support. This system consists of temperature sensor LM35, ADC 0804, microcontroller 89S51, fan and LCD for efficient and accurate results of control and monitor as simulation on proteus as well as hardware (Zong and Bao, 2010). On average the body temperature of birds is between 41 and 42.2°C. Body temperature is kept quite constant and is regulated by part of the chicken brain (the hypophyse) this part of the brain is comparable to a thermostat (effective heating system for poultry house 2005).

Contraction and widening of blood vessels and the speed of respiration influence the body temperature, it take some time before heat regulating mechanisms start functioning in new born animals and therefore they need a higher ambient temperature than adult animal do, the ratio between the surface area and weight of young animals unfavorable and they do not have any fat reserves (Effective Heating System for Poultry House, 2005).

### Materials and Methods

The automatic fish feeder complete circuitry is been analyzed here with the different modules in focus.

#### Power supply

This is the circuit that supplies power to the full system. It obtains its power source from a 220 voltas ac power supply source, to deliver a 5 volts dc power output. The circuit diagram is shown in Fig 1.

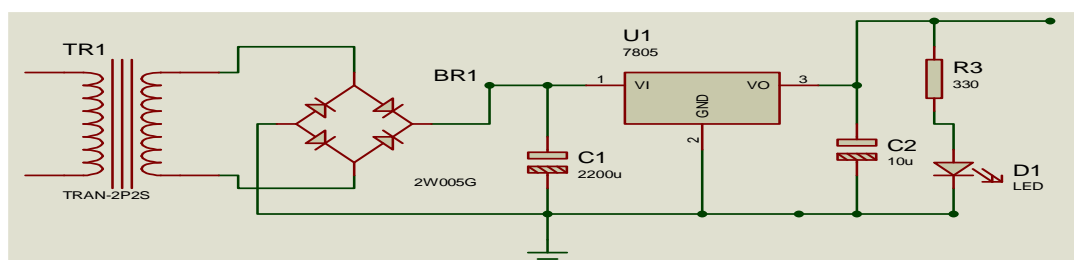

Fig. 1: The power supply unit

**TRI:** This is the step down transformer. A transformer voltage of 12Vac or above is required. The current should be enough to supply the requirement of the circuit.

The transformer (T1) chosen is 12Vac at 300mA.

**D1-D4:** These are the rectifier circuit. The diodes chosen must have a peak inverse voltage (PIV) that must be able to withstand twice the peak voltage ( $V_p$ ) of the transformers output and a forward current ( $D_c$ ) of 1.5 times the output current of the transformer.

$$V_p = \sqrt{2}V_{rms} \dots\dots\dots (1.1)$$

Where  $V_p$  is the peak voltage of the transformer output.

$V_{rms}$  is the actual output voltage from the transformer = 12Vac

$$V_p = \sqrt{2} \times 12 = 16.97V$$

$$D_{(piv)} = 2 \times V_p \dots\dots\dots (1.2)$$

Where  $D_{(piv)}$  is the PIV of the rectifier diode

$$\text{Therefore, } D_{(piv)} = 2 \times 16.97 = 33.94.$$

$$\text{And } D_c = 1.5 \times 300 \times 10^{-3} = 0.45A$$

Therefore the required diode must have a:

$$PIV \geq 33.94V$$

$$D_c \geq 0.45A$$

From diode catalogue, the IN4007 has the following characteristics:

$$PIV = 50V$$

$$D_c = 1A$$

Consequently, the diode chosen is the IN4007

$$D1-D4 = IN4007$$

**C1:** This is the filters capacitor. Electrolytic capacitors come with a capacitance and a voltage rating.

**Voltage Rating**

The voltage of the capacitor ( $V_c$ ) must be able to withstand 150% of the output voltage from the diode.

$$V_c = 150\% \text{ of } V_{DP} \dots\dots\dots (1.3)$$

Where  $V_{DP}$  is the peak output voltage from the diodes

But  $V_{DP}$  is given as

$$V_{DP} = V_p - V_D \dots\dots\dots (1.4)$$

**Where:**  $V_p$  is the peak voltage of the transformer;  $V_D$  is the voltage drop of the diodes ( $0.7 \times 2$ );  $V_{DP} = 16.97 - 1.4 = 15.57V$

$$\therefore V_c = 1.5 \times V_{DP} \dots\dots\dots (1.5)$$

$V_c$  is the voltage rating of the capacitor

$$V_c = 1.5 \times 15.57 = 23.6V$$

1.1.2 Capacitance Rating:

The capacitance of the capacitor must be such that it could reduce the ripple voltage ( $V_R$ ) to about 30% of the output peak voltage from the diodes.

$$V_R = 30\% \text{ of } V_{DP} \dots\dots\dots (1.6)$$

From eqn.(1.1),  $V_{DP}$  is given as 15.57

$$\therefore V_R = \frac{30}{100} \times 15.57$$

$$V_R = 4.67V \dots\dots\dots (1.6a)$$

From the ripple voltage equation ( $V_R$ ), we could get the capacitance

$$V_R = \frac{I_{max}}{2 \times f \times C_1} \dots\dots\dots (1.7)$$

**Where**  $V_R$  is the ripple voltage

$I_{max}$  is the maximum current from the diodes/ transformers (300mA)

$f$  is the frequency of supply (50Hz)

$C$  is the capacitance of the capacitor in Farads.

$$V_R = 4.67V \text{ (from eqn 1.6a)}$$

$$\therefore V_R (2FC) = I_{max}$$

$$C_1 = \frac{I_{max}}{V_R \times 2 \times f} \dots\dots\dots (1.8)$$

Substituting the value into the formula

$$C_1 = \frac{300 \times 10^{-3}}{4.67 \times 2 \times 50} = 6.42 \times 10^{-4} \text{ F}$$

Converting to  $\mu F$

$$C_1 = \frac{6.42 \times 10^{-4}}{10^{-6}} = 642.4 \mu F$$

This value cannot be obtained in the market and due to the high ripple rejection factor of the voltage regulator, a lower capacitance could be chosen. Therefore the capacitance chosen is:

$$C_1 = 470 \mu F \text{ at } 35V$$

U1: This is the voltage regulator.

Regulator specifications:

- i. Maximum input voltage = 30V
- ii. Maximum output voltage = 5.5V
- iii. Operating temperature = 0% - 150%

For effective Voltage regulation, the minimum input voltage should be:

$$V_{min} = V_{out} + V_{ref} \dots\dots\dots (1.9)$$

$V_{min}$  – Minimum input voltage

$V_{out}$  – required output voltage: 5V

$V_{ref}$  – Datasheet Stipulated reference voltage; 3V

$$V_{min} = 5V + 3V = 8V$$

The output voltage after the capacitor is 15.57 volts. This is enough to supply the minimum input voltage (8 volts). Therefore, the voltage regulator could be comfortably used. The regulator chosen is;

$$U_1 = 7805$$

**C2** is a transient capacitor. The rating is stipulated in the 7805 voltage regulator's data sheet as 0.1 $\mu F$

Hence,

$$C_2 = 0.1 \mu F$$

This capacitor helps for smoothening of the output from the voltage regulator. It is also to prevent spikes in the DC output voltage waveform in the event of transient disturbances. It is known as a buffer capacitor whose value is gotten from the data sheet of the regulator.

Current limiting resistor calculation:

$$R_1 = (V_s - V_d) / I_d \dots\dots\dots (1.10)$$

$$R_1 = (5 - 2) / 10 \times 10^{-3} = 300 \Omega$$

This value of resistor is not in Alaba market (Lagos), so the appropriate value to use is:

$$R_1 = 330 \Omega$$

Light emitting diode characteristics:

Forward current of..... $10 \times 10^{-3} A$  to  $10 \times 10^{-3} A$

Voltage drop of.....2V

**Indicator**

This is the circuit that shows the status of the system. The circuit diagram is as shown below.

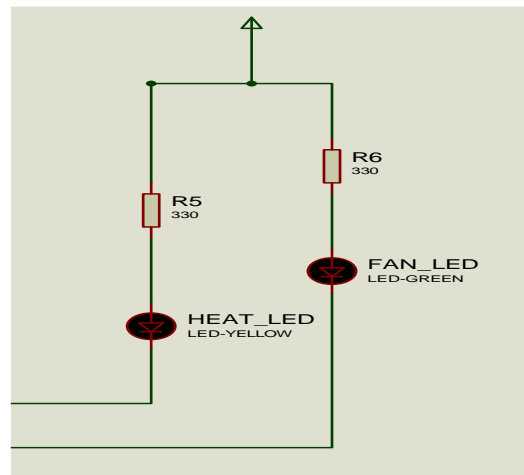

**Fig. 2: Indicator unit**

$R_x$  = current limiting resistor;  $R_x = V_s - V_D / I_D$

**Where**

$V_s$  = supplied voltage (5V);  $V_D$  = voltage drop across LED (2V)

$I_D$  = safe operating current for LED 10mA to 20mA

Complete circuit

Figure 3 displays a complete circuit diagram of automatic temperature regulator.

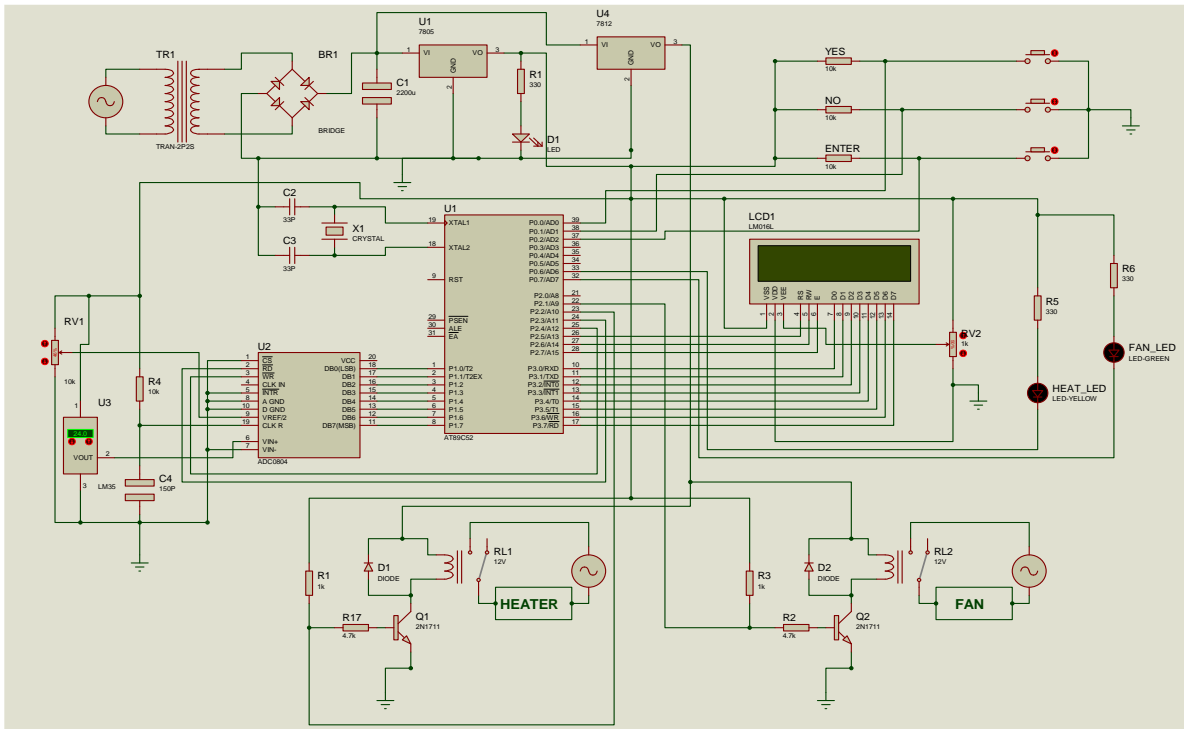

Fig. 3: Complete circuit diagram of automatic temperature regulator



Plate 1: Showing the complete design of automatic temperature regulator

Mode of operation

An Atmel 8052 microcontroller is the background base of the system which is the center of operation that is responsible in the programming of the sensing unit (LM35 IC) which senses the temperature values when decreased or increased in the temperature control unit that indicates the values with the aid of liquid crystal display (LCD). The center for the operation is the temperature sensor which is used in the regulation of the temperature, when the temperature drops it regulate it by triggering the lighting source (200W incandescent bulb) from the temperature control unit and the temperature will regulate back to its normal range value of temperature programmed or

instructed by an Atmel 8052 microcontroller. The value of the sensor ranges from -50 to 45°C. When the power supply unit is used to burst up the system it make use of 12V input and it distribute power to the different units to produce an output of 5V to the system.

Conclusion

Temperature increases or decreases from normal value, control elements such as cooling fan or heater are used to regulate this increase and decrease in temperature value effectively and these values are displayed on the LCD. Thus, it is important to maintain temperature of a localized area

according to desire of poultry farm. This system is not only feasible in poultry farm but can also be installed in livestock career to save life of animals. In future, by using different types of sensors, this system can be enhance to control and monitor other environmental parameters like humidity, feeding of livestock's, turbidity, pH etc. It will make our system more reliable in near future which is a dire need of food and agriculture industry for its growth.

**Conflict of Interest**

The authors declare that there is no conflict of interest related to this study.

**References**

May JD & Lott BD 2001. Relating weight gain and feed. Gain of male and female broilers to rearing temperature. *Poultry Science*, 80: 581-584.

Rupesh IM, Sanket ND, Megha AC & Nivedita PW 2004. PLC based poultry automation system. *Int. J. Sci. and Res.*, 3:3.

Sravanth G & Abraham S 2015. Internet based smart poultry farm. *Indian J. Sci. and Techn.*, 19: 101.

Zong Q & Bao W 2010. The dairy cattle data acquisition system based on PDA. *Institution of Electrical and Electronics Engineering (IEEE) World Automation Congress (WAC)*, 65: 69 - 77.

Effective Heating Systems for Poultry Houses 2005. *World Poultry*, 22:2.